

MDV

Mixing Degas Vessel

Installation Manual for MDV SEC-50

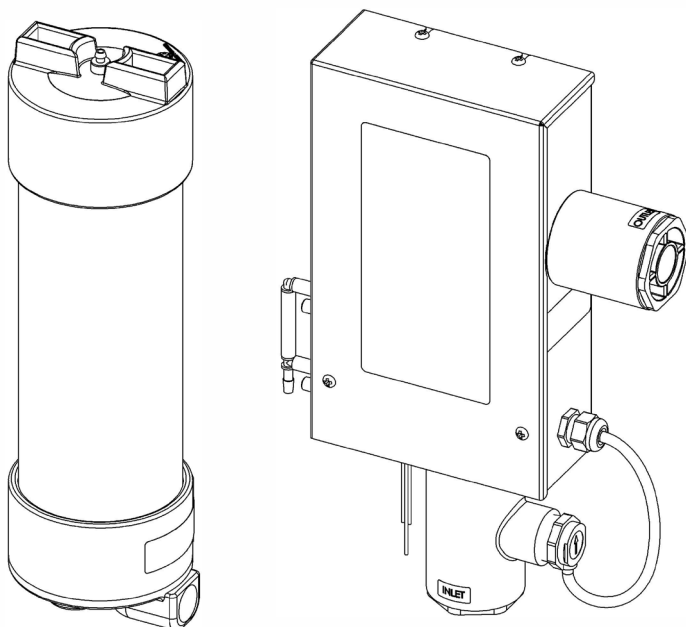

DEL **ozone**™
advanced **sanitation solutions**

EPA Estab. No. 071472-CA-001

 (800) 676-1335

 o3info@delozone.com

 www.delozone.com

4-2550-01 Rev.A

TABLE OF CONTENTS

SECTION 1 General Information.....	1
SECTION 2 Installation	1
SECTION 3 Operation.....	3
SECTION 4 Troubleshooting.....	3
SECTION 5 Maintenance.....	4
SECTION 6 Replacement Parts.....	4
Warranty	5

MDV for SEC-50

SECTION 1 General Information

The DEL MDV (Mixing Degas Vessel) system:

- Prevents virtually all ozone bubbles from returning to the pool, which eliminates bubble noise and visibility.
- Allows application of higher ozone concentrations.
- Protects pool components such as covers, fittings, and surfaces.
- Prevents bubbles from gathering under the cover or inside plumbing.
- Utilizes an ozone destruct cartridge with Granulated Activated Carbon (GAC). This destroys excess ozone gas removed by the MDV.

SECTION 2 Installation (refer to Figure 1)

NOTE: The MDV will not be as effective in systems with back pressures in excess of 10 psi. Oversized pumps and small returns should be avoided.

1. Follow **SECTION 2** installation instructions in the SEC-50 manual.
NOTE: There are additional parts for the MDV installation (compare **Figure 2** in the SEC-50 manual with **Figure 1** in this manual). The additional installation steps specific to the MDV parts are described below.
2. Mount the MDV vertically as shown in **Figure 1** to a solid surface (i.e. fence, wall, post) using the (2) cable ties, (4) cable tie mounts, and (4) screws included. Use a pair of pliers to tighten and secure the cable tie. If trimming away excess, fold tab over to avoid the sharp edge. To avoid discoloration, mount in an area out of direct sunlight.
3. Mount the Ozone Destruct vertically to a flat surface using (2) #6 screws.
NOTE: Mount it close enough to the MDV so that the tubing can be connected from the Ozone Destruct to the top of the MDV.
4. Install By-Pass plumbing as shown in **Figure 1**.
5. An additional valve may be installed either before or after the MDV to act as a drain for winterizing or maintenance.

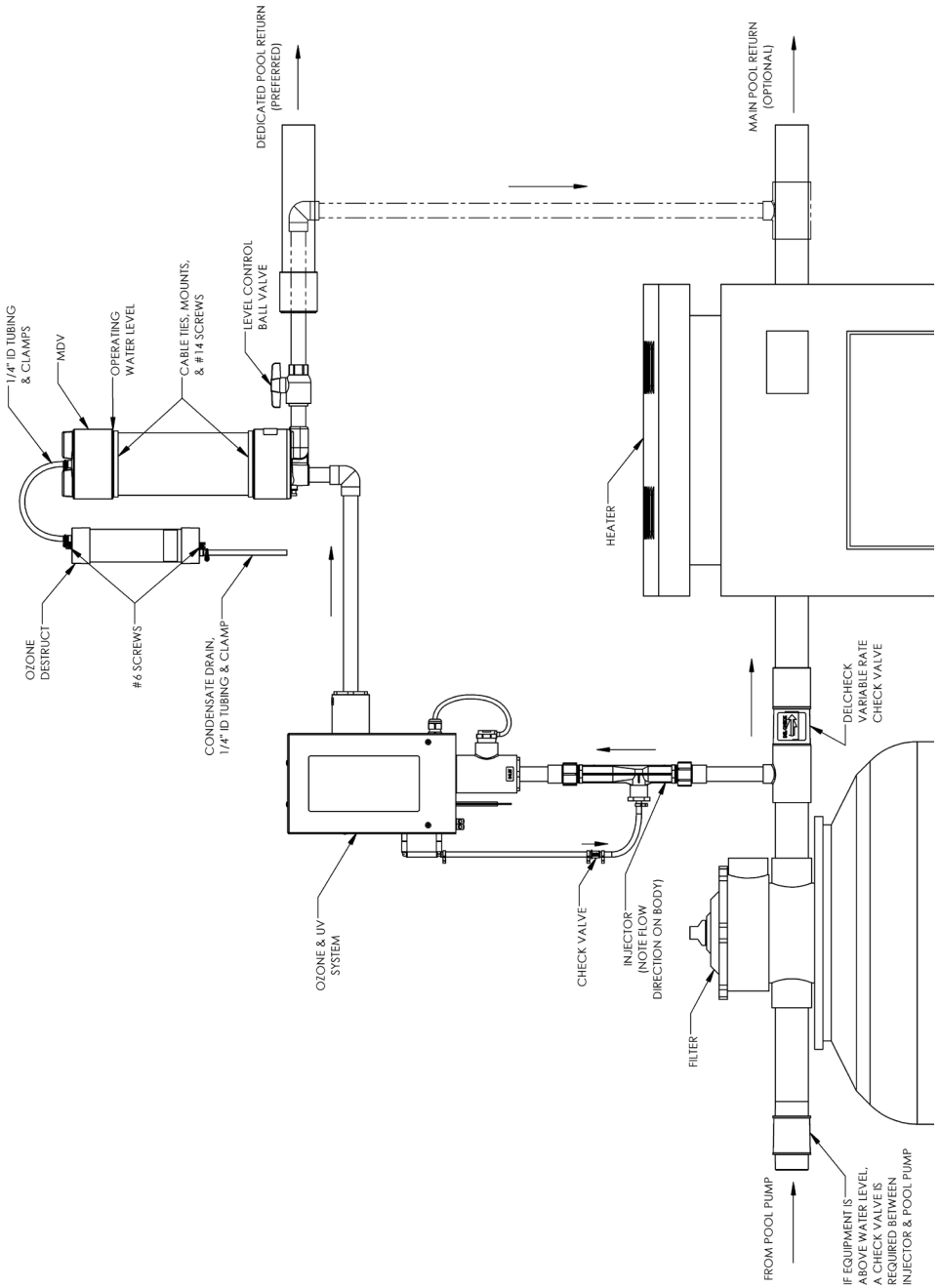

Figure 1: Typical Plumbing with MDV (pool with heater)

6. The drain at the base of the Destruct cartridge will release small amounts of condensation and carbon under normal operation. To avoid water or carbon stains, connect tubing to the bottom of the Destruct and divert the condensation to a suitable location.
7. Allow all PVC glue to dry completely, per manufacturer's instructions, before running water through MDV.

SECTION 3 Operation

1. The water level inside the MDV should be near the bottom edge of the MDV Top Endcap. Use the Level Control Ball Valve installed at the MDV outlet to adjust the water level (see Troubleshooting section).

NOTE: For Variable Speed pumps, the water level in the MDV may drop completely at low speeds. The Level Control Ball Valve may be closed slightly to raise the level. However, this may impair injector performance at higher speeds. Verify proper operation under all conditions.

2. Streams of gas bubbles should be rising to the top of the MDV, and the water returning to the pool should be virtually bubble free.
3. If the pool equipment is mounted above water level, it is normal for water to drain from the MDV when the main circulation pump turns off. The MDV should return to normal operation shortly after the system comes back on.

SECTION 4 Troubleshooting

Symptom: The water level in the tower is only around half full, or steadily dropping.

There is not enough backpressure downstream of the MDV to maintain water level in the tower. Plumb in a small ball valve downstream of the MDV. Close it off to the point where the proper water level in the tower is maintained.

SECTION 5 Maintenance

1. The MDV itself is maintenance free. The ozone destruct cartridge must be replaced every 12 months of operation. A new one can be ordered from your dealer/distributor using DEL part number 9-0620.
2. Winterizing, if necessary, can be done by draining water from the MDV.

SECTION 6 Replacement Parts

Hose Clamp for 1/4" ID tubing	2-0078
Cable Tie (for mounting MDV)	8-0668
Ozone Destruct	9-0620

DEL OZONE LIMITED ONE YEAR WARRANTY

The limited warranty set forth below applies to products manufactured by DEL OZONE and sold by DEL OZONE or its authorized dealers. This limited warranty is given only to the first retail purchaser of such products and is not transferable to any subsequent owners or purchasers of such products.

DEL Ozone warrants that it or its authorized dealers will repair or replace, at its option, any part of such products proven to be defective in materials or workmanship within ONE (1) year from the date of retail purchase of such products. (All parts) ANY REPAIR OR REPLACEMENT WILL BE WARRANTED ONLY FOR THE BALANCE OF THE ORIGINAL WARRANTY PERIOD OR NINETY (90) DAYS, Whichever is greater.

NOTE: USE ONLY DEL AUTHORIZED DEL REPLACEMENT PARTS. USE OF ANY OTHER PART(S) WILL VOID THIS WARRANTY.

Any replaced parts must be returned to DEL OZONE for warranty evaluation.

THIS LIMITED WARRANTY DOES NOT INCLUDE ANY OF THE FOLLOWING:

- (a) Any labor charges for troubleshooting, removal, or installation of such parts.
- (b) Any repair or replacement of such parts necessitated by faulty installation, improper maintenance, improper operation, misuse, abuse, negligence, accident, fire, flood, repair materials, and/or unauthorized accessories.
- (c) Any such products installed without regard to required local codes and accepted trade practices.
- (d) Damage to unit caused by water backflow.
- (e) Any implied warranty of merchantability or implied warranty of fitness for particular purpose, and such warranties are hereby disclaimed.
- (f) DEL Ozone shall not be liable under any circumstances for loss of use of such product, loss of profits, direct damages, indirect damages, consequential damages, and / or incidental damages.

This warranty gives you specific legal rights. You may have other rights which vary from state to state.

TO OBTAIN WARRANTY SERVICE:

DEL OZONE

Customer Service Number:

(800) 676-1335

Fax Number:

(805) 541-8459

E mail

warrantysupport@delozone.com
service@delozone.com

(residential)
(commercial)

PROVIDE:

1. **Customer name, mailing address, and telephone.**
2. **Installer/Mechanical Contractor or Dealer name.**
3. **Unit Part Number, Serial Number or Manufacture Date, and date of purchase.**
4. **The date of failure.**
5. **A description of the failure.**

After this information is provided, DEL Ozone may release a *RETURN GOODS AUTHORIZATION (RGA) NUMBER*. After receiving the RGA number the part in question must be returned to DEL Ozone, freight prepaid, with the RGA number clearly marked on the outside of the package. All preauthorized defective parts must be returned to DEL Ozone within thirty (30) days. Under no circumstances may any product be returned to DEL Ozone without prior authorization. Returns without the assigned RGA number on the outside of the package will be refused and shipped back to the sender at their expense. Upon receipt of preauthorized returned goods, DEL Ozone will repair or replace, at DEL Ozone's option, the defective product(s) and return them (freight prepaid for products under warranty). Buyer's acceptance of the product and use thereof constitutes acceptance of these terms.

DEL ozoneTM
advanced **sanitation solutions**

EPA Estab. No. 071472-CA-001

 (800) 676-1335

 o3info@delozone.com

 www.delozone.com