

aquaCLIPSE™

ZO-400 Series Installation & Operations Manual



DEL Ozone™
advanced sanitation solutions

IMPORTANT SAFETY INSTRUCTIONS

READ AND FOLLOW ALL INSTRUCTIONS

- Read this manual completely before attempting installation.
- All permanent electrical connections should be made by a qualified electrician.
- For cord and plug-connected units, connect to a GFCI or RCD protected grounding type receptacle only.
- Do not bury cord.
- Warning - To reduce the risk of electrical shock, replace damaged cord immediately.
- Follow all applicable electrical codes.
- Electric shock hazard. Be sure to turn power OFF and disconnect from power source before any service is performed. Failure to do so could result in serious injury or death.
- Warning - Short-term inhalation of high concentrations of ozone and long term inhalation of low concentrations of ozone can cause serious harmful physiological effects. DO NOT inhale ozone gas produced by this device.
- For your safety, do not store or use gasoline, chemicals or other flammable liquids or vapors near this or any other appliance.

SAVE THESE INSTRUCTIONS!

TABLE OF CONTENTS

SECTION 1 General Information

1A. Description	1
1B. Specifications	2

SECTION 2 Installation

2A. Recommended Installation.....	2
2B. Electrical.....	4

SECTION 3 Controls

3A. Power	4
3B. Timer	4

SECTION 4 Water Treatment..... 5

SECTION 5 Maintenance & Service

5A. System Electromechanical Overview.....	6
5B. Cleaning the Dispersion Stone.....	6
5C. Troubleshooting	7

Warranty	9
----------------	---

SECTION 1 General Information

1A. Description

The DEL Ozone Aquaclipse Corona Discharge (CD) ozonator is designed to pump ozone gas into liquids for purification on new, existing or multiple well water tanks. Enjoy refreshing, crystal clear water that's free of chlorine, chemical byproducts and chemical residue as the unit eliminates hydrogen sulfide odor along with 99.9-99.999% of the microorganisms found in well water, including *E. coli*, *Giardia* and *Cryptosporidium*.

What's in the box?

1. Aquaclipse Ozone Generator
2. Parts Bag (P/N 9-1190-01)
 - a. Squeeze Clamp (P/N 7-0021)
 - b. Squeeze Clamp x2 (P/N 7-1453-01)
 - c. Check Valve & Tubing Assembly (P/N 9-0796-01)
 - d. 3/8" ID Tubing (P/N 7-1430-01)
 - e. Manual (P/N 4-2191-01)
 - f. Dispersion Stone (P/N 7-1513-01)

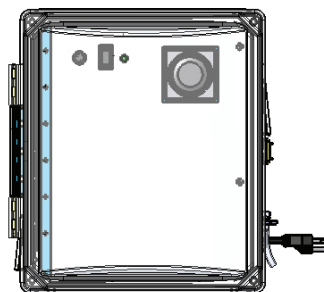

Aquaclipse Ozone Generator

1B. Specifications**Compressor Flow**

15 SCFH @ 10 psi

Power Requirements

ZO-400: 120VAC, 60Hz, 1Ø, 2.3A
 ZO-400-25: 230VAC, 50Hz, 1Ø, 1.3A

Shipping Weight

ZO-400: 25 lbs. (11.6 kg)
 ZO-400-25: 26 lbs. (11.8 kg)

Mounting

Wall mount in clean, protected area

Ambient Temperature

30°F – 100°F (-1°C – 38°C)

SECTION 2 Installation**2A. Recommended Installation for wells & holding tanks****Refer to Figure 1 (Next Page)**

1. The ZO-400 must be securely mounted to a clean surface sheltered from direct exposure to the elements (rain, sun and dirt). Mount above the maximum water level, if possible. Mounting hardware is not included.
2. Attach the check valve and tubing assembly to the barb fitting coming out from the bottom right side of the ZO-400. Make sure the flow arrow on the check valve points away from the ZO-400

- and toward the water tank. Soften the tubing if necessary by dipping it in warm water.
3. Connect one end of the tubing supplied in the parts bag to the larger end of the check valve and tubing assembly. Connect the other end of the tubing to the dispersion stone.
4. Place the Dispersion Stone into the center of the water vessel approximately 1 foot from the bottom for maximum ozone saturation in the water. It is best to put a sinker weight on the stone to keep it from floating up and use string to keep it from sinking all the way to the bottom of the tank. Note: The Dispersion Stone is delicate. Be sure to place it where it will not be stepped on or crushed.
5. If the generator is mounted below the water line, a water trap loop must be used. To make a water trap loop, simply coil the tubing into a 6" circle, (**Figure 1**), and fasten it above the water line. The plastic check valve provided should be installed in the ozone supply tubing between the generator and the loop, and secured with tubing clamps. Be sure that the flow arrow on the check valve points toward the tank.

CAUTION: Small amounts of nitric acid may collect in the ozone supply tubing during normal operation. When servicing or replacing tubing wear proper safety equipment and avoid bodily contact with condensation.

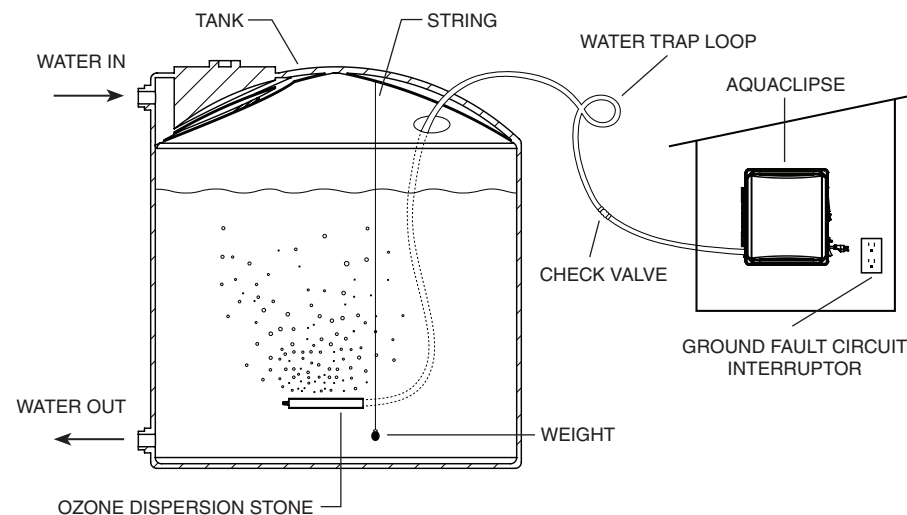
**Figure 1: Recommended Installation**

2B. Electrical

Simply plug the ZO-400 into a properly rated receptacle, installed to applicable electrical codes. The receptacle must be protected by a GFCI or RCD.

SECTION 3 Controls

3A. Power

The DEL Ozone Aquaclipse has a power switch on the front panel for turning the system on and off. The light next to the switch will illuminate when the system is powered on.

3A-1 Indicator lights

1. System Power – The green light in between the timer and the switch will light up when the switch is in the on position and the system has power.
2. Ozone Modules – To view the Ozone Module lights, open the Access Panel as described in Section 5A. Turn power on briefly to view lights.

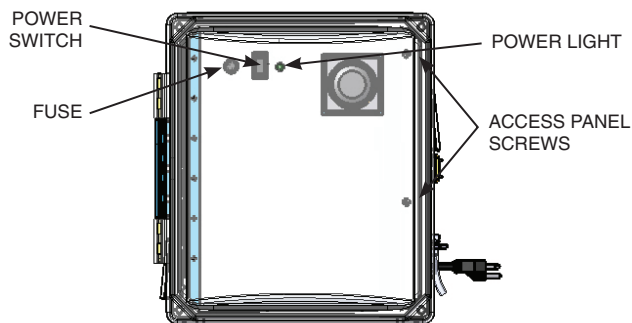

DO NOT touch the ZO-400 or the internal components while unit is operational.

3B. Timer

The ZO-400 is equipped with a built-in timer to control the operation of the ozone generator. The timer has 96 moveable tabs, each representing a 15 minute period of operation. Push the tabs INWARD to turn ON the ozonator, and OUTWARD to turn it OFF.

To use the timer, remove the plastic cover and depress enough consecutive tabs on the dial for the desired operating time. For example, four consecutive tabs need to be pushed in for one hour of operation (**Figure 1**). Plug in the ZO-400 and turn the main power switch on. Rotate the timer clockwise. When the first depressed tab reaches the pointer in the center of the timer, the ozonator will turn on. The ozonator will turn off again upon reaching the first undepressed tab, or when the main power switch is turned off.

The timer will continue to run as long as the ZO-400 is plugged in, even if the power switch is off. You can set the time of day by rotating the dial clockwise until the correct time is lined up at the pointer.

SECTION 4 Water Treatment

The ZO-400 Aquaclipse can purify water in atmospheric tanks, emergency storage, spas, bathtubs, fountains, and wading pools up to 20 feet deep. It is specifically designed to purify drinking water from well sources or city water supplies, removing undesirable tastes, odors and colors caused by iron, copper, manganese, chlorine and organics. The Aquaclipse is especially good at removing the sulfur smell from well water.

DO NOT use water from a source that is questionable such as stagnant pool water, creeks, ponds, streams, urinary tracts or the like.

To treat water, place the dispersion stone into the water container as shown in Figure 1 and set the timer to make the unit run for the amount of time desired (recommended 24 hr/day operation). Running the unit less than 24 hours per day may work for your set-up, but running the unit for longer will not hurt the water or the system.

When used in conjunction with a particulate filter, ozone will also remove excess minerals including iron, manganese, and lead, as well as radon and sulfur gases. It is recommended you check your filters about 1 month after installation of ozone equipment to gage rate of clogging.

Ozone will extend the useful life of both water vessels and equipment since it is impossible to over-treat the water. In contrast, a single overdose of chlorine can do serious damage.

NOTE: Although installing ozone on potable water tanks will reduce or eliminate bacteria problems, it is not recommended as a replacement to standard disinfection treatment.

SECTION 5 Maintenance & Service

5A. System Electromechanical Overview

5A-1 Internal Component

To access the internal components of the Aquaclipse, turn off the Power Switch, disconnect power to the unit, then unlatch and fully open the Front Cover. Remove the two Access Panel screws and carefully swing the panel open.

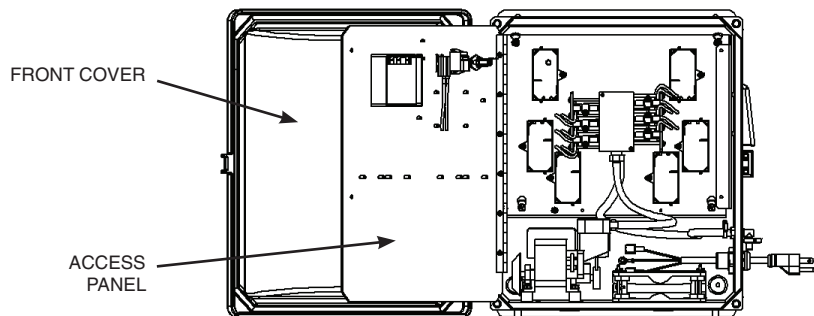

To order replacement parts, refer to **Figure 2** for part numbers and descriptions.

5B. Cleaning the Dispersion Stone

Periodically, the dispersion stone may clog up with mineral deposits reducing the amount of ozone flow through the stone. The stone will appear a darker color. Remove the dispersion stone. Soak it in lemon juice or vinegar for a few hours to overnight until the discoloration is gone and the dispersion stone is a uniform color. Rinse the dispersion stone thoroughly with fresh water. Reinstall the dispersion stone.

NOTE: Sometimes the stain will be permanent; if ozone bubbles still flow from the dispersion stone the stain will not affect operation.

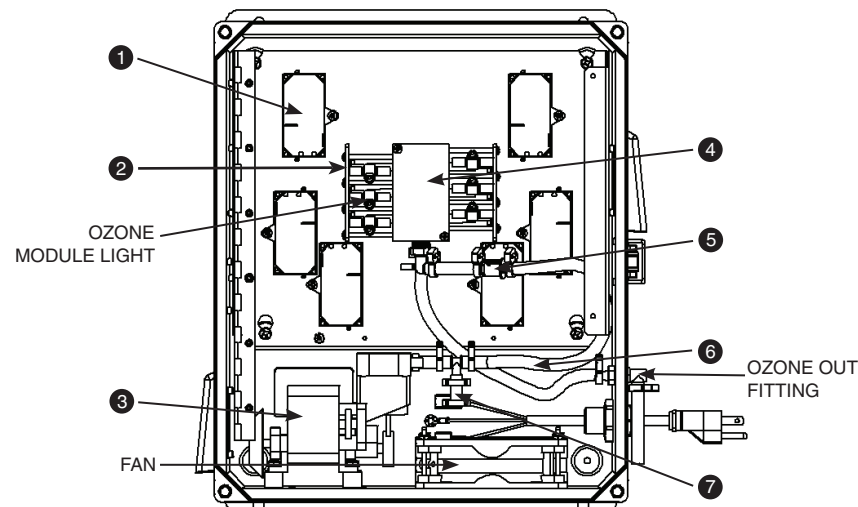

Figure 2: ZO-400 Internal View

#	Description	Part Number
1	Ozone Module	9-1056-01
2	Manifold Mounting Bracket	8-1191-01
3	Compressor (120V models)	5-1936-01
	Compressor (230V models)	5-1936-02
4	Ozone Cell Manifold	8-1159-02
5	Check Valve	7-1256-03
6	Tubing, 1/4"IDx3/8"OD	7-0964
7	Pressure Relief Valve	7-1419-01
8*	Fuse (120v)	5-4013
	Fuse (240V)	5-0458

*Not shown in Figure 2, refer to Section 3A

5C. Troubleshooting

The areas to check on the ZO-400 to determine the nature of a problem are as follows:

1. The green power light on the front panel – should be on if the system is in operation.
2. There should be air bubbles in the water.

3. The fan on the bottom of the ZO-400 – should be on when the system is in operation.
4. The condition of the water – should be clear and odor-free.

5C.1 SYMPTOM: green power light off – system not functioning

Probable cause	Corrective action
No power to unit	Check power source and cord
Tripped circuit breaker	Reset circuit breaker
G.F.C.I. tripped	Reset G.F.C.I.
Fuse Blown	Replace fuse
Defective electrical system	Return for service/repair

5C.2 SYMPTOM: Ozone Module Light not lit

Probable cause	Corrective action
Ozone module dead	Replace ozone module (Note: system will run fine with a bad ozone module; ozone production will be decreased.)
Ozone module disconnected	Check electrical connection to Ozone module

5C.3 SYMPTOM: everything works correctly, but water is dirty

Probable cause	Corrective action
Excessive load	If extra high load is normal, continue 24hr. Operation and compliment with small amount of chlorine treatment
pH not balanced	Adjust pH to 7.2 to 7.8
Total alkalinity incorrect	Adjust total alkalinity to 80 – 150 PPM
Dirty, loose, or cracked filter	Replace filter
Clogged dispersion stone	Clean or replace dispersion stone (see section 5B)
Kink, leak, or break in ozone tubing	Remove kinks or replace tubing
Run time insufficient	Increase run time

**DEL OZONE
LIMITED ONE YEAR WARRANTY**

The limited warranty set forth below applies to products manufactured by DEL OZONE – 3580 Sueldo Street, San Luis Obispo, California 93401, and sold by DEL OZONE or its authorized dealers. This limited warranty is given only to the first retail purchaser of such products and is not transferable to any subsequent owners or purchasers of such products.

DEL Ozone warrants that it or its authorized dealers will repair or replace, at its option, any part of such products proven to be defective in materials or workmanship within ONE (1) year from the date of retail purchase of such products. (All parts) ANY REPAIR OR REPLACEMENT WILL BE WARRANTED ONLY FOR THE BALANCE OF THE ORIGINAL WARRANTY PERIOD OR NINETY (90) DAYS, Whichever is greater.

NOTE: USE ONLY DEL AUTHORIZED DEL REPLACEMENT PARTS. USE OF ANY OTHER PART(S) WILL VOID THIS WARRANTY.

Any replaced parts must be returned to DEL OZONE for warranty evaluation.

THIS LIMITED WARRANTY DOES NOT INCLUDE ANY OF THE FOLLOWING:

- (a) Any labor charges for troubleshooting, removal, or installation of such parts.
- (b) Any repair or replacement of such parts necessitated by faulty installation, improper maintenance, improper operation, misuse, abuse, negligence, accident, fire, flood, repair materials, and/or unauthorized accessories.
- (c) Any such products installed without regard to required local codes and accepted trade practices.
- (d) Damage to unit caused by water backflow.
- (e) Any implied warranty of merchantability or implied warranty of fitness for particular purpose, and such warranties are hereby disclaimed.
- (f) DEL Ozone shall not be liable under any circumstances for loss of use of such product, loss of profits, direct damages, indirect damages, consequential damages, and / or incidental damages.

This warranty gives you specific legal rights. You may have other rights which vary from state to state.

TO OBTAIN WARRANTY SERVICE:

DEL OZONE
 3580 Sueldo, San Luis Obispo, CA 93401
 Customer Service Number: (800) 676-1335
 Fax Number: (805) 541-8459
 E mail: warrantysupport@delozone.com (residential)
 service@delozone.com (commercial)

PROVIDE:

1. Customer name, mailing address, and telephone.
2. Installer/Mechanical Contractor or Dealer name.
3. Unit Part Number, Serial Number or Manufacture Date, and date of purchase.
4. The date of failure.
5. A description of the failure.

After this information is provided, DEL Ozone may release a RETURN GOODS AUTHORIZATION (RGA) NUMBER. After receiving the RGA number the part in question must be returned to DEL Ozone, freight prepaid, with the RGA number clearly marked on the outside of the package. All preauthorized defective parts must be returned to DEL Ozone within thirty (30) days. Under no circumstances may any product be returned to DEL Ozone without prior authorization. Returns without the assigned RGA number on the outside of the package will be refused and shipped back to the sender at their expense. Upon receipt of preauthorized returned goods, DEL Ozone will repair or replace, at DEL Ozone's option, the defective product(s) and return them (freight prepaid for products under warranty). Buyer's acceptance of the product and use thereof constitutes acceptance of these terms.



3580 Sueldo Street, San Luis Obispo, CA 93401

(800) 676-1335

o3info@delozone.com

www.delozone.com

EPA Estab. No. 071472-CA-001