



DEL UV-C 50

**INSTALLATION INSTRUCTIONS
& PRODUCT MANUAL**

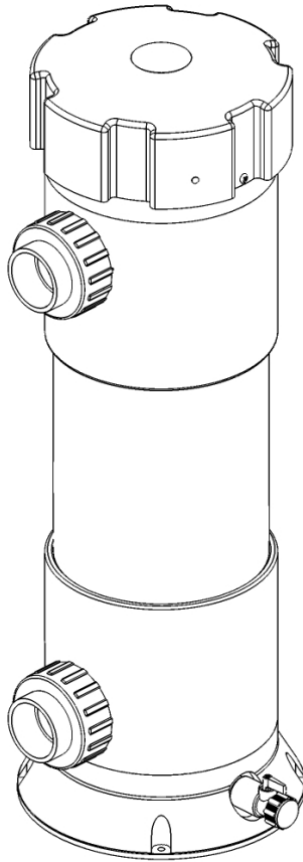

TABLE OF CONTENTS

SECTION 1 General Information

1A. Description	1
1B. Specifications	1
1C. Unpacking.....	1

SECTION 2 Installation

2A. Pool Preparation	2
2B. Location	2
2C. Mounting	2
2D. Plumbing.....	2
2E. Electrical	3

SECTION 3 Operation

3A. Initial System Start-Up	7
3B. Normal Operation.....	7
3C. System Shut-Down.....	8
3D. Winterizing	8
3E. Water Chemistry.....	8

SECTION 4 Maintenance & Service

4A. System Maintenance	8
4B. Quartz Tube Removal and Cleaning	10
4C. Quartz Tube Installation.....	11
4D. Re-installing the UV Lamp(s)	11

TABLE OF CONTENTS

SECTION 5 Troubleshooting

5A. Troubleshooting.....	12
--------------------------	----

SECTION 6 Contact Information

6A. Contact Information.....	13
------------------------------	----

6B. Ordering Information.....	13
-------------------------------	----

6C. Standard Replacement Parts List.....	13
--	----

FAQs.....	14
------------------	-----------

IMPORTANT SAFETY INSTRUCTIONS

READ & FOLLOW ALL INSTRUCTIONS

- Read this manual completely before attempting installation. Failure to install in accordance with the installation instructions could void warranty and result in injury or death.
- All permanent electrical connections should be made by a qualified electrician.
- **⚠ CAUTION** Follow all applicable electrical codes.
- **⚠ DANGER** Electric shock hazard. Be sure to turn power OFF and disconnect from power source before any service work is performed. Failure to do so could result in serious injury or death.
- The UV-C 50 main power is to be connected to pool controls that are protected by a Ground Fault Circuit Interrupter (G.F.C.I.).
- For units equipped with a power cord, do not bury the cord.
- **⚠ WARNING** To reduce risk of electric shock, always plug cord directly into outlet. Do not use an extension cord.
- The UV-C 50 must be installed so that the orientation is exactly as shown in **Figure 2**.
- **⚠ WARNING** Mount the UV-C 50 so that it is inaccessible to anyone in the pool. Never attempt any servicing while unit is wet.
- **⚠ DANGER** This unit contains Ultraviolet (UV) Lamps. Prolonged exposure to UV can cause severe burns to eyes and skin.
- **⚠ CAUTION ENVIRONMENTAL NOTICE:** Hg-Lamp CONTAINS MERCURY. Manage in accordance with disposal laws. See: www.lamprecycle.org
- Do not defeat the safety features on the unit intended to prevent inadvertent UV exposure.
- **⚠ CAUTION** For your safety, do not store or use gasoline, chemicals, flammable liquids or vapors near this or any other appliance.
- To maintain cosmetic integrity, protect this unit from direct prolonged sunlight exposure.
- **⚠ WARNING** To reduce the risk of injury, do not permit children to use this product.

IMPORTANT SAFETY INSTRUCTIONS

READ & FOLLOW ALL INSTRUCTIONS

- **GROUNDING INSTRUCTIONS** - This unit must be grounded. In the event of a malfunction or breakdown, grounding will reduce the risk of electric shock by providing a path of least resistance for electric current. This unit is equipped with a cord having an appliance-grounding conductor and a grounding plug. The plug must be plugged into an appropriate outlet that is installed and grounded in accordance with all local codes and ordinances.
-  **WARNING** Improper connection of the appliance-grounding conductor can result in a risk of electric shock. Check with a qualified electrician or service representative if you are in doubt whether the unit is properly grounded. Do not modify the plug provided with the appliance. If it will not fit the outlet, have a proper outlet installed by a qualified technician.
- This product conforms with the applicable provisions of the United States Code of Federal Regulations requirements, including Title 21, Chapter I, Subchapter J, Radiological Health.

SAVE THESE INSTRUCTIONS!

Section 1 General Information

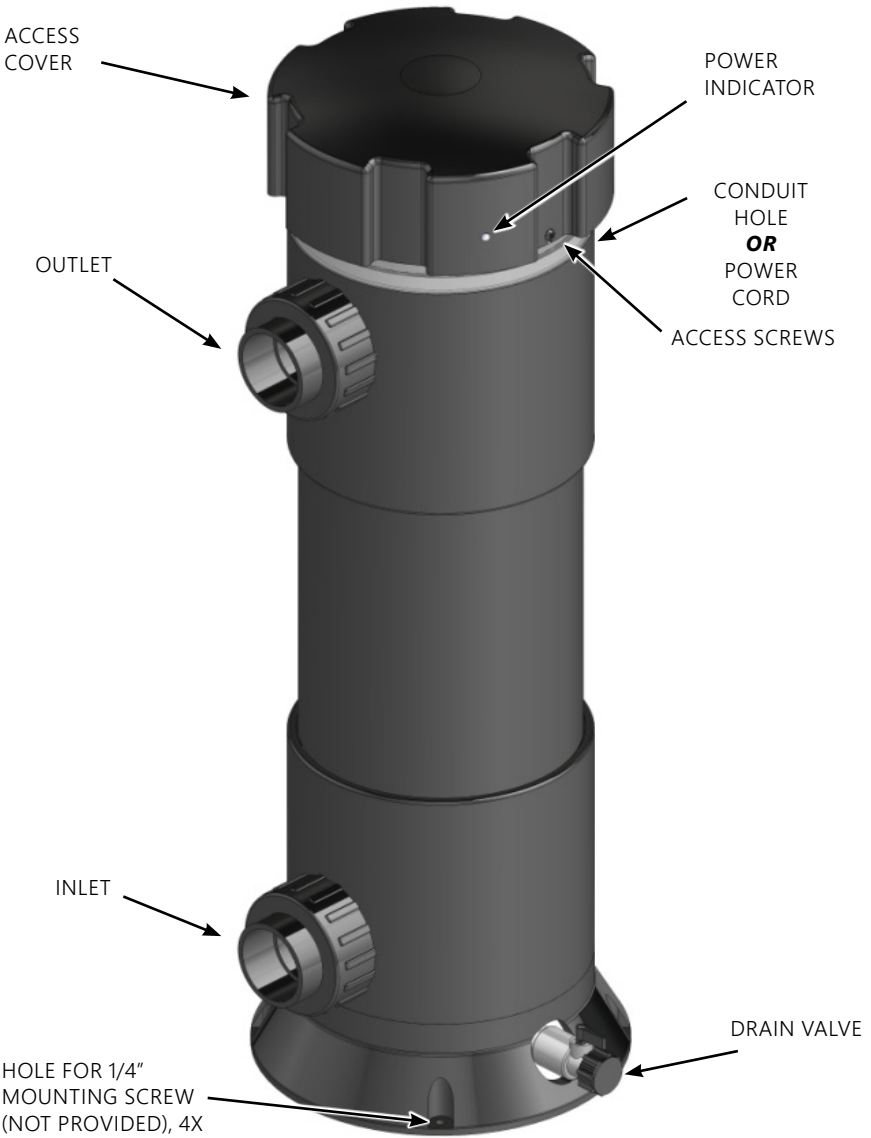

Figure 1: Overview

Section 1 General Information

1A. Description

The DEL UV-C 50 System described in this manual is designed to provide the benefits of UV treated water in an environmentally safe and effective manner. The high quality, specially engineered components ensure efficient water sanitization output and reliable performance. The UV-C 50 includes two germicidal UV lamps tuned to 254nm, and is safe and harmless to your equipment and bathers when installed properly.

1B. Specifications

Power Requirements:

120/240 VAC, 0.8/0.4A, 96W, 50/60Hz

Shipping Weight:

Approx: 28 lb

Location Requirements:

Mounting: Floor Mounted

Ambient Temp.: 35°F – 104°F (2°C – 40°C)

Max Flow Rate: 100 GPM (189 LPM)

This product is designed for supplemental disinfection and should be used with registered or approved disinfection chemicals.

1C. Unpacking

Carefully remove the unit from the shipping box. The UV-C 50 Lamps are protected from water by Quartz Tubes sealed into the UV Housing (see **Figure 5**). Remove the Access Cover as described in **Section 2D** and visually inspect the Quartz Tubes for damage. If there are any indications of cracks or broken Tubes, contact Customer Service for replacement.

Section 2 Installation

2A. Pool Preparation

To achieve optimal performance from the UV-C 50 system, the pool should be cleaned prior to installation.

1. Backwash or clean filters one day before starting the UV-C 50.
2. Superchlorinate pool water using a chlorine based shock treatment so the water has a sustained 1-3 ppm free chlorine level.
3. Test pool chemistry and adjust pH between 7.4 and 7.6. Adjust total alkalinity between 80 and 120 ppm.
4. Run pool filtration continuously for 24 hours prior to starting the UV-C 50.

2B. Location

The UV-C 50 is designed for floor mounting. Locate the unit in a clean, protected area, either indoors or outdoors (preferably out of direct sunlight). If possible, locate the unit out of reach of sprinklers or drainage spouts. Allow sufficient access for maintenance (3 ft clearance above and 1 ft around the unit), plumbing and electrical hookups.

2C. Mounting

Use the four (4) mounting holes provided in the base of the UV-C 50 to secure it onto a solid, level surface.

2D. Plumbing

Use a size 2 Phillips screwdriver to loosen the two Access Screws on the Access Cover. Lift the Access Cover and tilt it over to expose the Power, Pressure Switch and Lamp Connectors. While holding the Cover, disconnect all of the connectors (4 total). Set the Access Cover aside.

The UV-C 50 can easily be added into the pool's plumbing loop. Simply connect the water inlet and outlet into the pool's return line.

Section 2 Installation

It is advised that you plumb the UV-C 50 before the heater. Bypass valves are recommended for winterization.

2D-1. Plumbing the UV-C 50

The UV-C 50 must be installed in the pool's main return line after the filter, preferably before the heater and any chlorine feeders or chlorine generators. Refer to **Figure 2** for a variety of installation configurations

The UV-C 50 will come with union fittings installed on the Inlet and Outlet. Use the union fittings provided to connect the UV-C 50 inlet and outlet to your pool's plumbing as shown in **Figure 2**. (Inlet is at the bottom, outlet is at the top)

NOTE: If the UV-C 50 is installed below water level, a Flow Switch Kit is required to ensure the system does not turn on without adequate flow. Contact Customer Service to order the kit.

2D-2. Leak Test

Once all plumbing connections are complete and glue has properly cured, start the circulation system and run at highest normal operating pressure. Check for leaks at all external connections, and inside the UV-C 50 housing near the Quartz Tube seals. Repair leaks as needed before proceeding to **SECTION 2E**. Electrical. If leaks persist at the union connectors or at the Quartz Tube seals, contact Customer Service.

When plumbing is complete, turn off circulation system and relieve pressure from the system.

2E. Electrical

2E-1. Main Power

NOTE: Refer to the **IMPORTANT SAFETY INSTRUCTIONS** at the beginning of this manual for very important wiring information before proceeding.

Section 2 Installation

NOTE: UV and Ozone installation diagrams are for reference purposes only. Contact technical support for any questions.

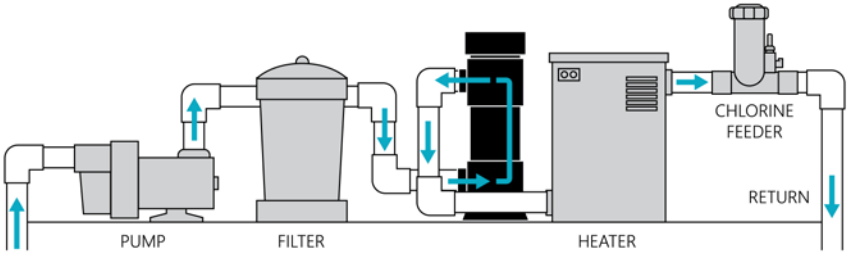

Figure 2a. UV-C 50 Direct Plumbing Location

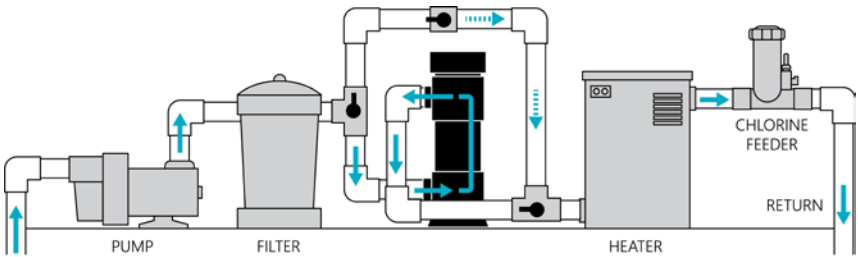

Figure 2b. UV-C 50 with Bypass Valve
optional bypass for service or winterization

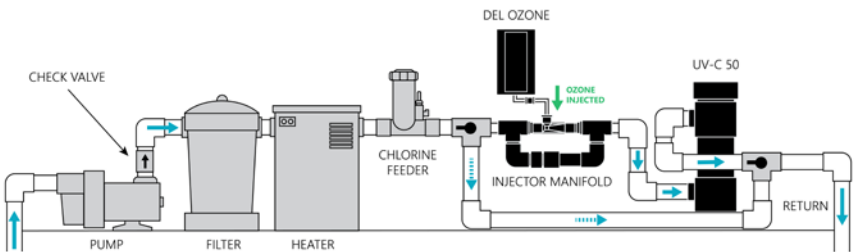

Figure 2c. UV-C 50 With Bypass Valve & Ozone Generator

Figure 2. UV-C 50 Install Diagrams

Section 2 Installation

Connect the UV-C 50 to the pool timing clock so that the UV-C 50 operates simultaneously with the pool pump.

For models equipped with a power cord, connect to an appropriate outlet that is install and grounded in accordance with all local codes and ordinances.

For hardwired models (no plug), run service wire from the pool timer into the UV-C 50 Wiring Housing. Use appropriate fittings suitable for wet locations (UL 514B) to meet local code requirements (for example, see **Figure 3**). Connect the service wires to the loose wires on the Power Connector harness.

- Black to Line 1
- White to Neutral or Line 2
- Green to ground

Once the service wires are connected to the harness wires, disconnect the Power harness at the provided locking connector.

2E-2. Installations Below Water Level

If the UV-C 50 is installed below water level, a Flow Switch Kit is required to ensure the system does not turn on without adequate flow. Contact Customer Service to order the kit (P/N EUV-FS-01).

2E-3. Reinstall The Access Cover

Reconnect all locking connectors and install the Access Cover. Ensure that the Cover Alignment Key is properly aligned with the mating feature on the UV-C 50 Housing.

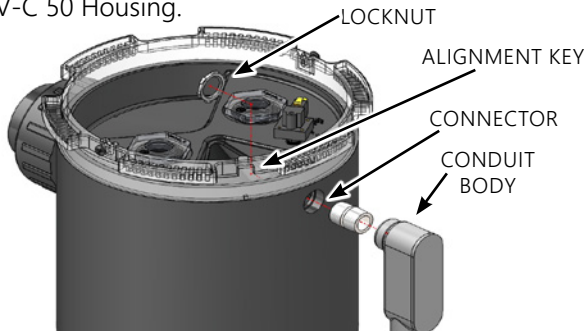

Figure 3: UV-C Wiring Housing

Section 3 Operation

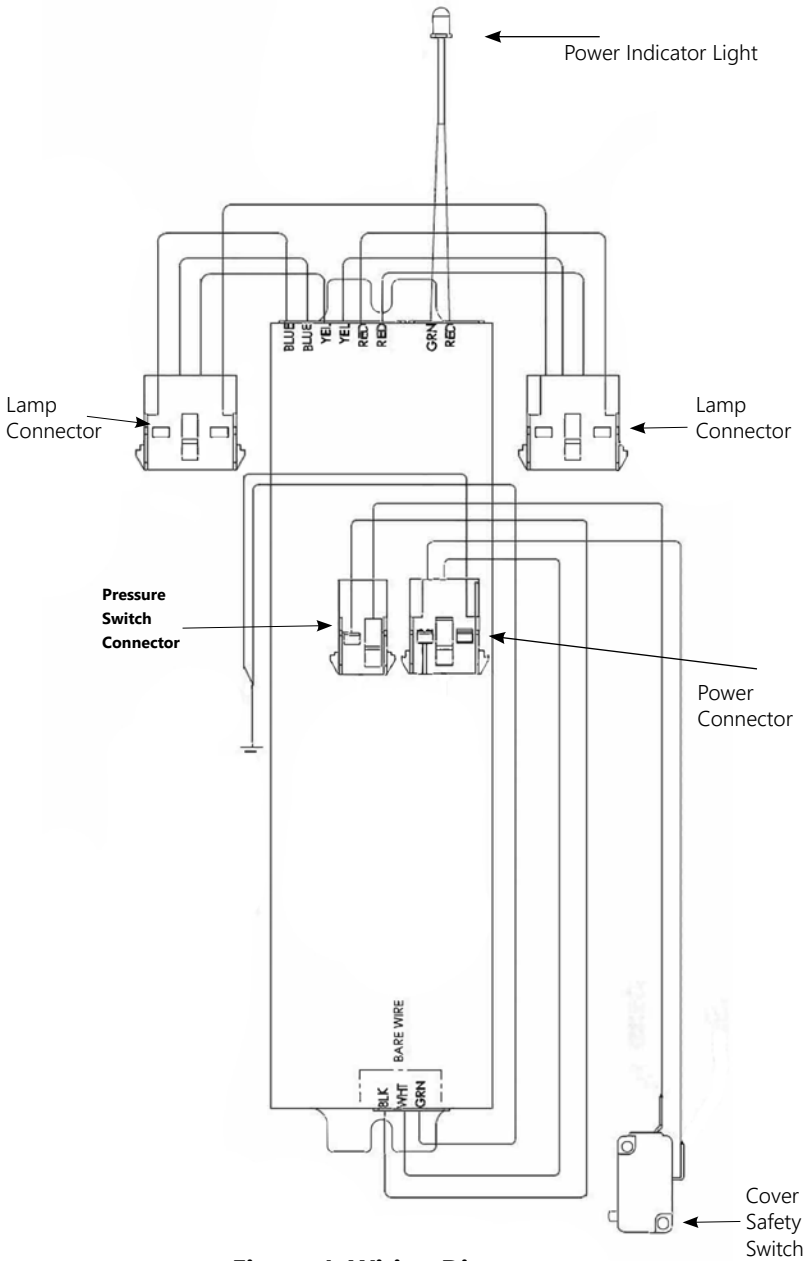

Figure 4: Wiring Diagram

Section 3 Operation

3A. Initial System Start-Up

Upon completing all of the system connections and cleaning the pool as outlined in **SECTION 2**, you are ready to start the UV-C 50.

1. Turn on the pool circulation system.
2. Verify that the green Power Indicator is lit.
3. Look through the clear Glow Ring in the Housing and verify that both UV Lamps are steadily lit. They should not flicker or turn off while the system is operating.
4. Turn off the pool circulation system and verify that the UV Lamps are no longer lit.
5. System is now ready for normal operation.

3B. Normal Operation

Indicator Lights: When the pool's circulation system starts, the UV-C 50 will power up and the green indicator light on the access cover will power on.

Glow Ring: The glow ring, located below the Access Cover will light up when the UV bulbs are active. This provides visual confirmation that the bulbs are working.

 **WARNING DO NOT** attempt to view the UV light directly.

NOTE: Corresponding glow of the UV Lamps does not necessarily indicate full intensity. Replace UV Lamps after 18 months of operation, and ensure Quartz Tubes are clean for best results. See **SECTION 4** for additional maintenance information.

3C. System Shut-Down

The following sequence of steps must be followed for servicing. For storage, follow the steps and disconnect all electrical, plumbing and mounting connections.

1. Shut off power at the breaker.
2. Close by-pass valves if below water level.

Section 3 Operation & Section 4 Maintenance & Service

3D. Winterizing

If the pool will be shutting down for the winter months and the UV-C 50 will remain exposed to freezing temperatures, the unit must be drained to prevent freeze damage to the wetted components. To drain the UV-C 50, see the following steps.

1. If the UV-C 50 is mounted below the water level, bypass valves must all be CLOSED to prevent pool water from draining through the unit.
2. Locate the Drain Valve (Refer to **Figure 1**), remove the cap, and open valve to completely drain the water from the UV-C 50. If necessary, loosen the top union fitting (water outlet) to facilitate draining.
3. Allow all the water to drain from the UV-C 50 before closing the Drain Valve.

3E. Water Chemistry

Regular water chemistry testing should be performed as usual. Maintain a chlorine residual of 1–3 ppm free chlorine, pH between 7.4 and 7.6 and total alkalinity between 80 and 120 ppm.

4A. System Maintenance

⚠ CAUTION **Disconnect power before performing service.** Refer to the Safety Instructions displayed in the front of this manual.

Use a size 2 Phillips driver to remove the Access Cover as needed.

NOTE: The UV-C 50 will not operate until the Access Cover is replaced. Allow lamps to cool prior to service. See **SECTION 6C** for maintenance intervals.

STANDARD MAINTENANCE INTERVALS			
PART	PART NUMBER	MAINTENANCE	INTERVAL
Quartz Tube Assembly	9-1416-01	Clean	Every 6 months
UV Lamps	9-1421-01	Replace	Every 18 months

Section 4 Maintenance & Service

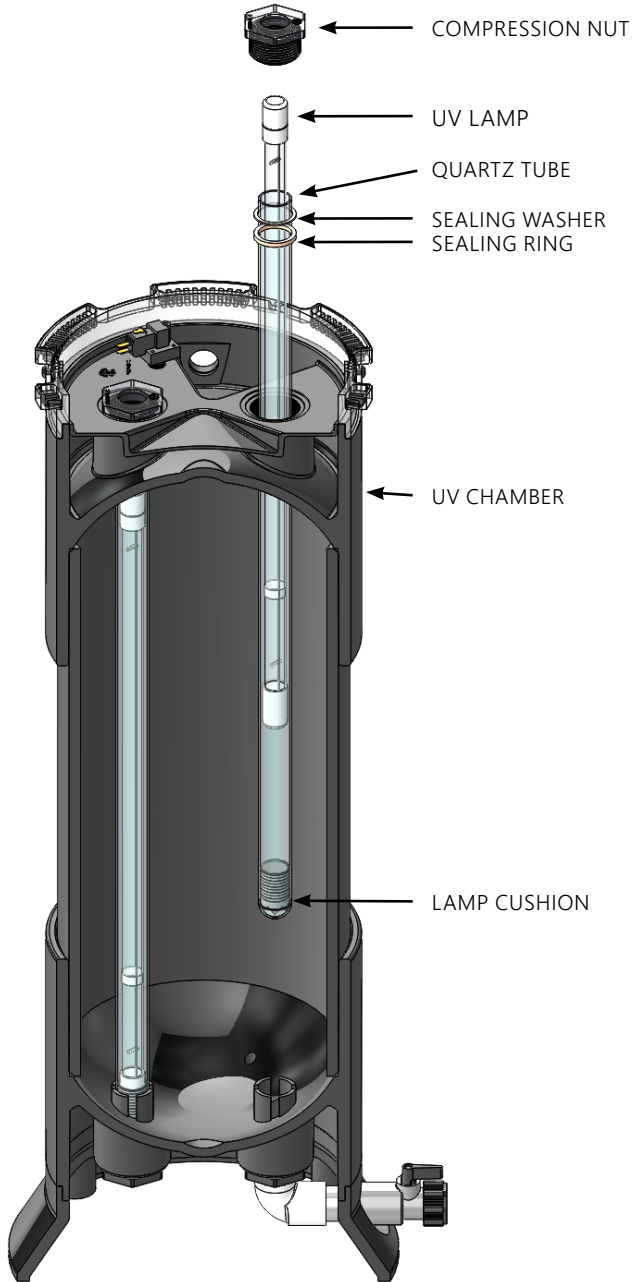

Figure 5: System Electromechanical Overview

Section 4 Maintenance & Service

4A-1. Removing Access Cover

The UV-C 50 may be serviced without disconnecting any of the plumbing or wiring. Simply use a Phillips screwdriver to loosen the two screws and remove the Access Cover. Disconnect Power Connector, two Lamp Connectors, and Pressure Switch Connector and set Access Cover aside.

4A-2. UV Chamber Service and Maintenance

The UV Lamps are housed in a Quartz Tube. If the Quartz Tube becomes dirty, its ability to transmit UV rays from the Lamp will be diminished. The Quartz Tube(s) should be removed from the UV Chamber every six (6) months and cleaned if necessary.

4A-3. Lamp Removal

NOTE: DO NOT TOUCH THE UV LAMP GLASS WITH YOUR BARE HANDS. Oils on your hands can cause hot spots on the UV Lamp and shorten its life. Use a soft clean cotton cloth or clean cotton gloves to handle the UV Lamp.

1. Grasp the UV Lamp wires and gently pull to remove the lamp from the tube.
2. Carefully place the UV Lamp in a clean, dry, and safe location. Repeat this process for the other UV Lamp.

4B. Quartz Tube Removal and Cleaning

NOTE: If the UV-C 50 is installed below water level, the bypass valves must be CLOSED to prevent pool water from draining through the Quartz Tube connection.

1. Drain the water from the UV Chamber (See **SECTION 3D**).
2. Verify that there is no pressure in the system.
3. Stand to the side of unit when removing the Access Cover. DO NOT place yourself or anything above the cover upon removal.
4. Use a wrench or socket to remove the compression nut.
5. Grasp the Quartz Tube from the top of the UV Chamber and pull

Section 4 Maintenance & Service

- to remove it from the UV Chamber.
6. Remove the Sealing Washer and Ring from the top of the Quartz Tube and set aside in a safe place. Inspect condition of Sealing Washer and Ring to ensure they are in good shape.
 7. Clean the Quartz Tube exterior with a mild solution of muriatic acid (available at all pool supply stores) and water in a ratio of four parts water to one part acid (4:1).

⚠ CAUTION Follow the directions for use and handling of muriatic acid on the acid bottle label. Always add acid to water, **NOT** water to acid. Protect your eyes, wear rubber gloves, and avoid breathing acid fumes.

NOTE: DO NOT USE ABRASIVE CLEANERS as they can scratch the high quality quartz glass. After cleaning the Quartz Tube, wash it off and wipe dry. Inspect the Quartz Tube for cracks. Replace if cracks are found. Make sure the inside of the Quartz Tube is dry before replacing the UV Lamps.

NOTE: Damages caused by broken quartz tubes are not covered under your limited warranty.

4C. Quartz Tube Installation

1. Hold the Quartz Tube vertically and insert the Quartz Tube into the UV Chamber until it is fully seated in the bottom of the UV Chamber.

NOTE: If the end of the Quartz Tube is protruding from the UV Chamber, the alignment is off. Remove and re-insert the Quartz Tube to seat it properly as shown in **Figure 5**.

2. Install the sealing ring followed by the steel sealing washer.
3. Place the Compression Nut over the Quartz Tube. Use a wrench or socket to install the compression nut approximately 1/4 turn past finger tight, and torque to approximately 15 in-lbs. **DO NOT OVER-TIGHTEN**. Turn the circulation pump ON and check the Quartz Tube seal for leaks.
4. Turn the circulation pump OFF once you have confirmed that the Quartz Tube is not leaking.

Section 5 Troubleshooting

4D. Re-installing the UV Lamp(s)

NOTE: Make sure to handle the UV lamp as described in **SECTION 4B**.

1. TURN OFF YOUR PUMP IF YOU HAVE NOT DONE SO.
2. Allow UV Lamp to drop slowly into the Quartz Tube until it is seated in the Lamp Cushion in the bottom of the tube.
3. Connect the Lamp Connectors, Pressure Switch Connectors and Power Connectors.

ENVIRONMENTAL NOTICE: Hg-Lamp CONTAINS MERCURY. Manage in accordance with disposal laws. See: www.lamprecycle.org

5A. Troubleshooting

Knowledge of electrical applications is required for troubleshooting. We recommend that a certified electrician service the equipment. Improper servicing will void generator warranty. If any condition persists contact Technical Support.

Symptom: Green Indicator not lit when pool system is on.

1. No power to the UV-C 50 from the Power Source:
 - a. Check circuit breaker at the power distribution box.
 - b. Check for loose connections or wiring breaks in the lines.
 - c. Indicator light may have burnt out.

Symptom: One or both the UV Lamps are not lit when unit it running.

1. Check Lamp Connector Plug for complete connection.
2. Water fouling has shorted lamp connections.
3. Bad UV Lamp.
4. Bad Ballast.

Section 6 Contact Information

6A. Contact Information

For technical assistance:

- Call: 1 (800) 676-1335
- Email: o3info@delozone.com

Be prepared with the following information:

- Name
- Address
- Model #
- Date Purchased

6B. Ordering Information

To locate a dealer near you, call us at 1 (800) 676-1335, and we'll be happy to help.

6C. Standard Replacement Parts List

1. **Quartz Tube Assembly, part #9-1416-01:** Clean every 6 months; replace as needed.
2. **UV Lamps, part # 9-1421-01:** Replace every 18 months.

Do I still need to use chemicals in the pool?

The UV-C 50 utilizes natural, ultraviolet light rays to destroy harmful contaminants in the water, including chlorine resistant *Cryptosporidium Parvum* and *Giardia*. We do recommend the use of a residual sanitizer as well to ensure ultimate swimmer-safety. A sustained 1-3ppm free chlorine level, pH between 7.4-7.6, and total alkalinity of 80-120ppm will provide a superior, modern pool experience with the integration of the UV-C 50.

How do I maintain a low chlorine residual in my pool?

A 1-3 ppm chlorine residual is maintained through a variety of methods, though an automatic chlorinator is the best choice to ensure a precise amount of chlorine is fed into the pool water as needed. The CMP line of automatic chlorinators are tuned to properly synchronize with DEL equipment. Contact CMP at 1 (800) 733-9060 to determine the proper chlorinator for your particular application.

How much maintenance is required?

Besides replacing the UV lamps (every 18 months), cleaning the quartz tubes (as needed), and wintering the unit, no other maintenance is typically needed. DEL solutions are proudly engineered with superior parts to provide simplistic maintenance, and low, long-term operations costs.

How do I explain what the UV-C 50 does?

The DEL UV-C 50 utilizes UV light rays that are tuned to a specific wavelength (254nm), which allows the light to destroy harmful bacteria, viruses, and chlorine-resistant microorganisms. This germicidal UV light, known as UV-C, is an environmentally friendly solution that allows us to highly reduce chlorine consumption and not leave behind any harmful by-products.



CMP, LLC
36 HERRING ROAD, NEWNAN, GA 30265
WWW.C-M-P.COM

0719ab