

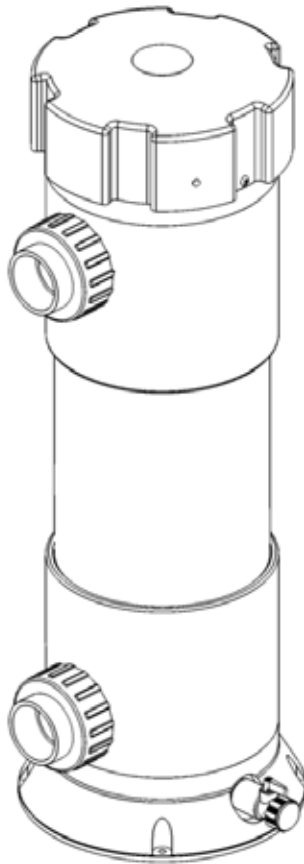

DEL UV-C 50

**INSTALLATION INSTRUCTIONS
& PRODUCT MANUAL**



C-M-P.COM/DEL

4-2612-01 Rev.A

TABLE OF CONTENTS

SECTION 1 General Information

1A. Description	1
1B. Specifications	1

SECTION 2 Installation

2A. Pool Preparation	3
2B. Location	3
2C. Mounting	3
2D. Plumbing	4
2E. Electrical	6

SECTION 3 Operation

3A. Initial System Start-Up	7
3B. Normal Operation	7
3C. System Shut-Down	8
3D. Winterizing	8
3E. Water Chemistry	8

SECTION 4 Maintenance & Service

4A. System Maintenance 9
4B. Quartz Tube Removal and Cleaning10
4C. Quartz Tube Installation.....12
4D. Re-installing the UV Lamp(s)12

SECTION 5 Troubleshooting

5A. Troubleshooting.....13

SECTION 6 Contact Information

6A. Contact Information 14
6B. Ordering Information..... 14
6C. Standard Replacement Parts List..... 14

IMPORTANT SAFETY INSTRUCTIONS

READ & FOLLOW ALL INSTRUCTIONS

- Read this manual completely before attempting installation. Failure to install in accordance with the installation instructions could void warranty and result in injury or death.
- All permanent electrical connections should be made by a qualified electrician.
- **⚠ CAUTION** Follow all applicable electrical codes.
- **⚠ DANGER** Electric shock hazard. Be sure to turn power OFF and disconnect from power source before any service work is performed. Failure to do so could result in serious injury or death.
- The UV-C 50 main power is to be connected to pool controls that are protected by a Ground Fault Circuit Interrupter (G.F.C.I)
- The UV-C 50 must be installed so that the orientation is exactly as shown in **Figure 2**.
- **⚠ WARNING** Mount the UV-C 50 so that it is inaccessible to anyone in the pool. Never attempt any servicing while unit is wet.
- **⚠ DANGER** This unit contains Ultraviolet (UV) Lamps. Prolonged exposure to UV can cause severe burns to eyes and skin.
- **⚠ CAUTION ENVIRONMENTAL NOTICE:** Hg-Lamp CONTAINS MERCURY. Manage in accordance with disposal laws.
See: www.lamprecycle.org
- Do not defeat the safety features on the unit intended to prevent inadvertent UV exposure.
- **⚠ CAUTION** For your safety, do not store or use gasoline, chemicals, flammable liquids or vapors near this or any other appliance.
- To maintain cosmetic integrity, protect this unit from direct prolonged sunlight exposure.
- **⚠ WARNING** To reduce the risk of injury, do not permit children to use this product.

SAVE THESE INSTRUCTIONS!

Section 1 General Information

1A. Description

The DEL UV-C 50 Sanitizer System described in this manual is designed to provide the benefits of UV treated water in an environmentally safe and effective manner. The high quality, specially engineered components ensure efficient water sanitization output and reliable performance. The UV-C 50 includes two germicidal UV lamps tuned to 254nm, and is safe and harmless to your equipment and bathers when installed properly.

1B. Specifications

Power Requirements:

120/240 VAC, 0.8/0.4A, 96W, 50/60Hz

Shipping Weight:

Approx: 28 lb

Location Requirements:

Mounting: Floor Mounted

Ambient Temp.: 35°F – 104°F (2°C – 40°C)

Max Flow Rate: 100 GPM (189 LPM)

This product is designed for supplemental disinfection and should be used with registered or approved disinfection chemicals.

Section 1 General Information

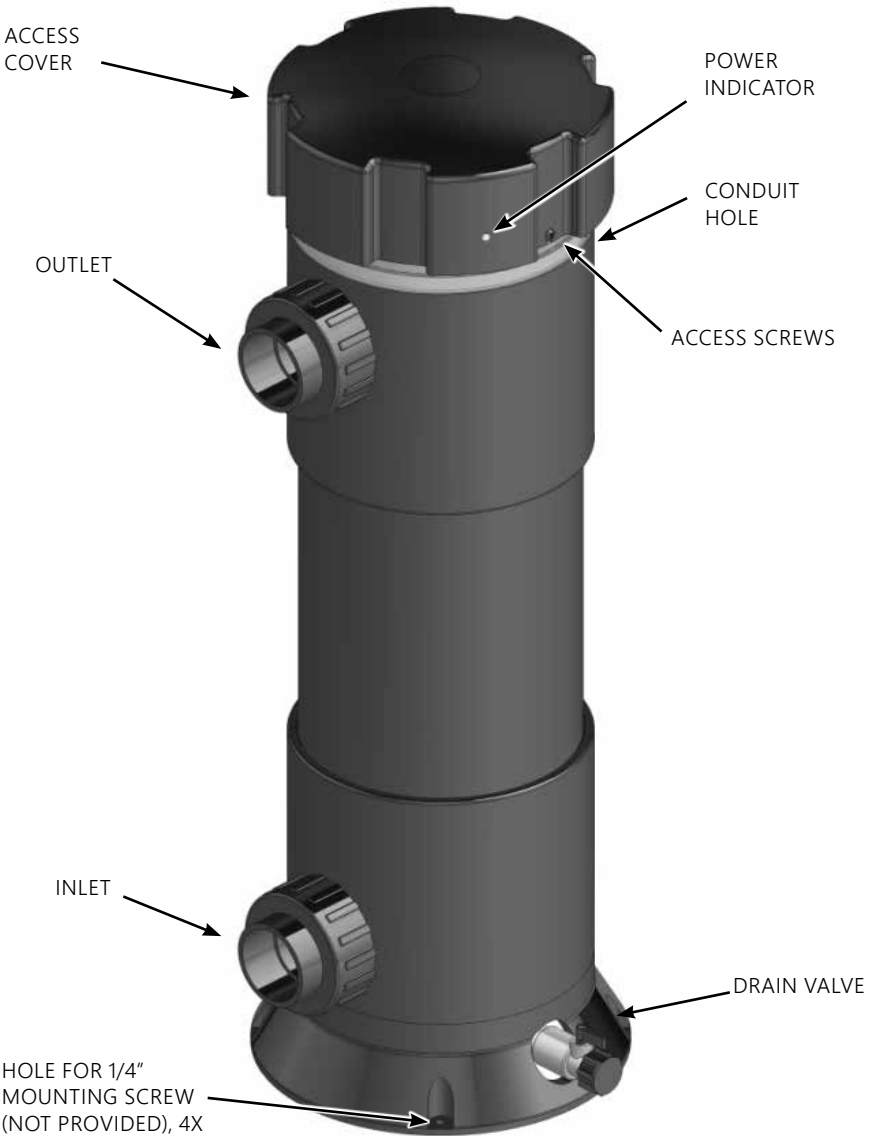

Figure 1: Overview

Section 2 Installation

2A. Pool Preparation

To achieve optimal performance from the UV-C 50 system, the pool should be cleaned prior to installation.

1. Backwash or clean filters one day before starting the UV-C 50.
2. Superchlorinate pool water using a chlorine based shock treatment so the water has a sustained 1-3 ppm free chlorine level.
3. Test pool chemistry and adjust pH between 7.4 and 7.6. Adjust total alkalinity between 80 and 120 ppm.
4. Run pool filtration continuously for 24 hours prior to starting the UV-C 50.

2B. Location

The UV-C 50 is designed for floor mounting. Locate the unit in a clean, protected area, either indoors or outdoors (preferably out of direct sunlight). If possible, locate the unit out of reach of sprinklers or drainage spouts. Allow sufficient access for maintenance (3 ft clearance above and 1 ft around the unit), plumbing and electrical hookups.

2C. Mounting

Use the four (4) mounting holes provided in the base of the UV-C 50 to secure it onto a solid, level surface.

Section 2 Installation

2D. Plumbing

Use a size 2 Phillips screwdriver to loosen the two Access Screws on the Access Cover. Lift the Access Cover and tilt it over to expose the Power, Pressure Switch and Lamp Connectors. While holding the Cover, disconnect all of the connectors (4 total). Set the Access Cover aside.

The UV-C 50 can easily be added into the pool's plumbing loop. Simply connect the water inlet and outlet into the pool's return line. It is advised that you plumb the UV-C 50 before the heater. Bypass valves are recommended for winterization.

2D-1. Plumbing the UV-C 50

The UV-C 50 must be installed in the pool's main return line after the filter, preferably before the heater and any chlorine feeders or chlorine generators. Refer to **Figure 2** for a variety of installation configurations

The UV-C 50 will come with one half of a union fitting installed on the Inlet and Outlet, the other half of the fittings will be located in the parts bag. Use the union fittings provided to connect the UV-C 50 inlet and outlet to your pool's plumbing as shown in **Figure 2**.

NOTE: If the UV-C 50 is installed below water level, a Flow Switch Kit is required to ensure the system does not turn on without adequate flow. Contact Customer Service (see **SECTION 6**) to order the kit.

2D-2. Leak Test

Once all plumbing connections are complete and glue has properly cured, start the circulation system and run at highest normal operating pressure. Check for leaks at all external connections, and inside the UV-C 50 housing near the Quartz Tube seals. Repair leaks as needed before proceeding to **SECTION 2E**. Electrical. If leaks persist at the union connectors or at the Quartz Tube seals, contact Customer Service (see **SECTION 6**)

When plumbing is complete, turn off circulation system and relieve pressure from the system.

Section 2 Installation

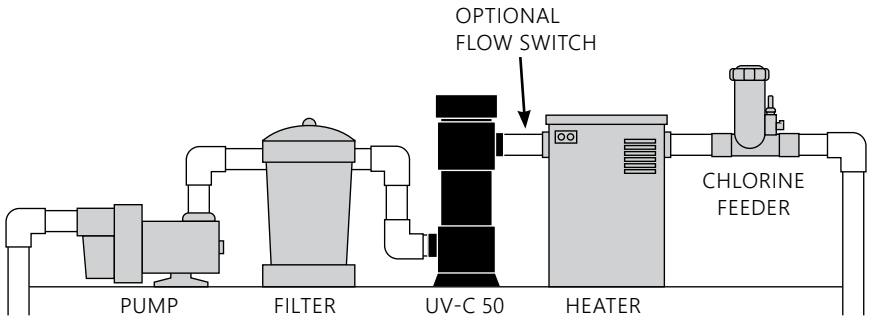

Figure 2a. UV-C 50 Direct Plumbing Location

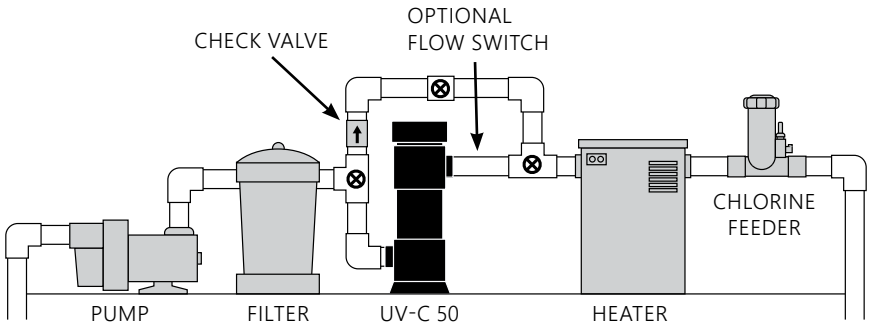

Figure 2b. UV-C 50 with Bypass Valve

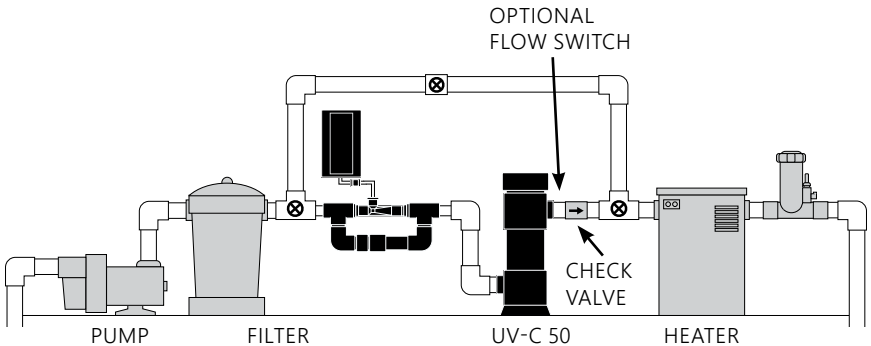

Figure 2c. UV-C 50 With Bypass Valve & Ozone Generator

Figure 2. UV-C 50 Install Diagrams

Section 2 Installation

2E. Electrical

2E-1. Main Power

NOTE: Refer to the **IMPORTANT SAFETY INSTRUCTIONS** at the beginning of this manual for important wiring information.

Connect the UV-C 50 to the pool timing clock so that the UV-C 50 operates simultaneously with the pool pump.

Run service wire from the pool timer into the UV-C 50 Wiring Housing. Use appropriate fittings as needed to meet local code requirements (for example, as shown in **Figure 3**). Connect the service wires to the loose wires on the Power Connector harness:

- Black to Line 1
- White to Neutral or Line 2
- Green to ground

Once the service wires are connected to the harness wires, disconnect the Power harness at the provided locking connector.

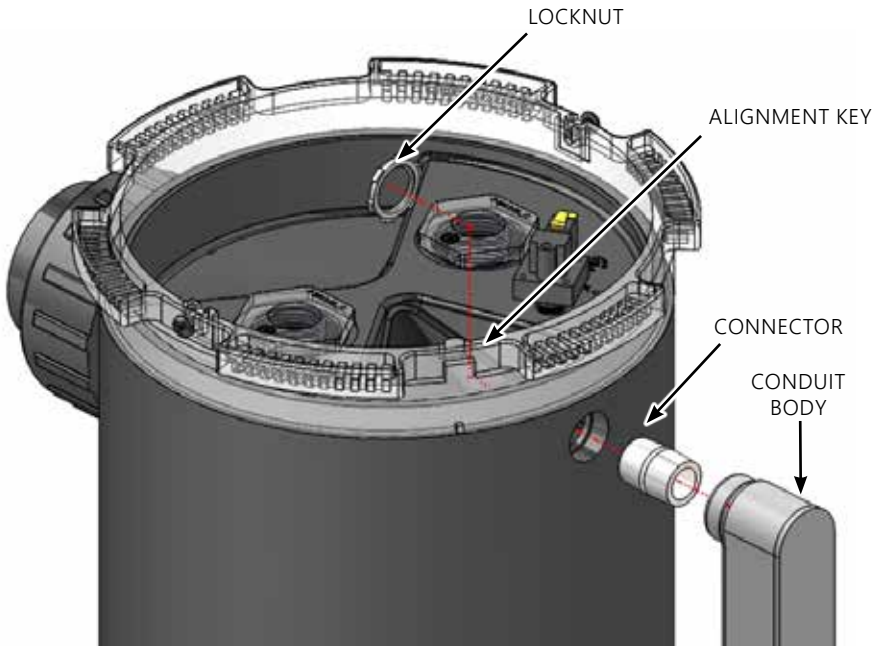

Figure 3: UV-C Wiring Housing

Section 2 & 3 | Installation & Operation

2E-2. Installations Below Water Level

If the UV-C 50 is installed below water level, a Flow Switch Kit is required to ensure the system does not turn on without adequate flow. Contact Customer Service (see **SECTION 6**) to order the kit.

2E-3. Reinstall The Access Cover

Reconnect all locking connectors and install the Access Cover. Ensure that the Cover Alignment Key is properly aligned with the mating feature on the UV-C 50 Housing.

3A. Initial System Start-Up

Upon completing all of the system connections and cleaning the pool as outlined in **SECTION 2**, you are ready to start the UV-C 50.

1. Turn on the pool circulation system.
2. Verify that the green Power Indicator is lit.
3. Look through the clear Glow Ring in the Housing and verify that both UV Lamps are steadily lit. They should not flicker or turn off while the system is operating.
4. Turn off the pool circulation system and verify that the UV Lamps are no longer lit.
5. System is now ready for normal operation.

3B. Normal Operation

Indicator Lights: When the pool's circulation system starts, the UV-C 50 will power up and the green indicator light on the access cover will power on.

Glow Ring: The glow ring, located below the Access Cover will light up when the UV bulbs are active This provides visual confirmation that the bulbs are working.

NOTE: Corresponding glow does not indicate full intensity. Always replace bulbs after 18 months.

Section 3 Operation

3C. System Shut-Down

The following sequence of steps must be followed for servicing or for storage.

1. Shut off power at the breaker.
2. Close by-pass valves if below water level.
3. Disconnect all electrical, plumbing and mounting connections

3D. Winterizing

If the pool will be shutting down for the winter months and the UV-C 50 will remain exposed to freezing temperatures, the unit must be drained to prevent freeze damage to the wetted components. To drain the UV-C 50, see the following steps.

1. If the UV-C 50 is mounted below the water level, bypass valves must all be CLOSED to prevent excess water from draining into the unit.
2. Locate the Drain Valve (Refer to **Figure 1**), remove the cap, and open valve to completely drain the water from the UV-C 50. If necessary, loosen the top union fitting (water outlet) to facilitate draining.
3. Allow all the water to drain from the UV-C 50 before closing the Drain Valve.

3E. Water Chemistry

Regular water chemistry testing should be performed as usual.

Maintain a chlorine residual of 1–3 ppm free chlorine, pH between 7.4 and 7.6, and total alkalinity between 80 and 120 ppm.

Section 4 Maintenance & Service

4A. System Maintenance

⚠ CAUTION Disconnect power before performing service. Refer to the Safety Instructions displayed in the front of this manual.

Use a size 2 Phillips driver to remove the Access Cover as needed.

NOTE: The UV-C 50 will not operate until the Access Cover is replaced. Allow lamps to cool prior to service.

See **SECTION 6C** for maintenance intervals

4A-1. Removing Access Cover

The UV-C 50 may be serviced without disconnecting any of the plumbing or wiring. Simply use a Phillips screwdriver to loosen the two screws and remove the Access Cover. Disconnect four electrical connectors and set the Access Cover aside.

4A-2. UV Chamber Service and Maintenance

The UV Lamps are housed in a Quartz Tube. If the Quartz Tube becomes dirty, its ability to transmit UV rays from the Lamp will be diminished. The Quartz Tube(s) should be removed from the UV Chamber every six (6) months and cleaned if necessary.

4A-3. Lamp Removal

NOTE: DO NOT TOUCH THE UV LAMP GLASS WITH YOUR BARE HANDS. Oils on your hands can cause hot spots on the UV Lamp and shorten its life. Use a soft clean cotton cloth or clean cotton gloves to handle the UV Lamp.

1. Grasp the UV Lamp wires and gently pull to remove the lamp from the tube.
2. Carefully place the UV Lamp in a clean, dry, and safe location. Repeat this process for the other UV Lamp.

Section 4 Maintenance & Service

4B. Quartz Tube Removal and Cleaning

NOTE: If the UV-C 50 is installed below water level, the bypass valves must be CLOSED to prevent pool water from draining through the Quartz Tube connection.

1. Drain the water from the UV Chamber (See **SECTION 3D**).
2. Verify that there is no pressure in the system.
3. Stand to the side of unit when removing the Access Cover. DO NOT place yourself or anything above the cover upon removal.
4. Use a wrench or socket to remove the compression nut.
5. Grasp the Quartz Tube from the top of the UV Chamber and pull to remove it from the UV Chamber.
6. Remove the Sealing Washer and Ring from the top of the Quartz Tube and set aside in a safe place. Inspect condition of Sealing Washer and Ring to ensure they are in good shape.
7. Clean the Quartz Tube exterior with a mild solution of muriatic acid (available at all pool supply stores) and water in a ratio of four parts water to one part acid (4:1).

⚠ CAUTION Follow the directions for use and handling of muriatic acid on the acid bottle label. Protect your eyes, wear rubber gloves, and avoid breathing acid fumes.

NOTE: DO NOT USE ABRASIVE CLEANERS as they can scratch the high quality quartz glass. After cleaning the Quartz Tube, wash it off and wipe dry. Inspect the Quartz Tube for cracks. Replace if cracks are found. Make sure the inside of the Quartz Tube is dry before replacing the UV Lamps.

NOTE: Damages caused by broken quartz tubes are not covered under your limited warranty.

Section 4 Maintenance & Service

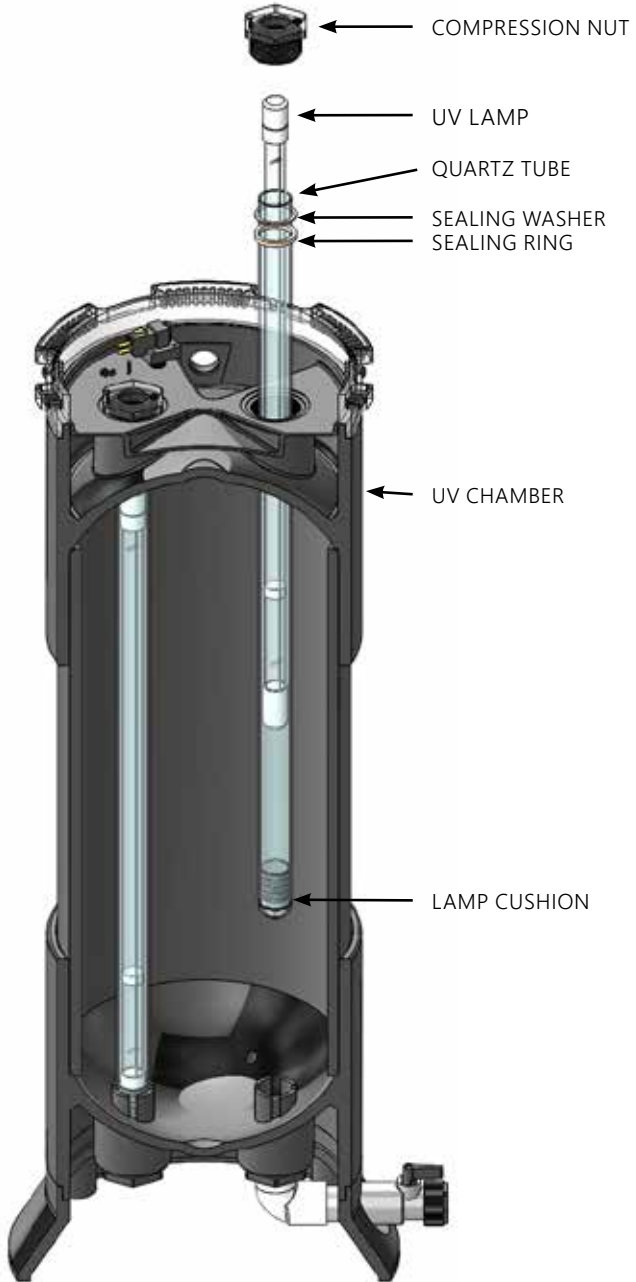

Figure 4: System Electromechanical Overview

Section 4 Maintenance & Service

4C. Quartz Tube Installation

1. Hold the Quartz Tube vertically and insert the Quartz Tube into the UV Chamber until it is fully seated in the bottom of the UV Chamber.

NOTE: If the end of the Quartz Tube is protruding from the UV Chamber, the alignment is off. Remove and re-insert the Quartz Tube to seat it properly as shown in **Figure 4**.

2. Install the sealing ring followed by the steel sealing washer.
3. Place the Compression Nut over the Quartz Tube. Use a wrench or socket to install the compression nut, and torque to approximately 15 in-lbs. **DO NOT OVERTIGHTEN**. Turn the circulation pump ON and check the Quartz Tube seal for leaks.
4. Turn the circulation pump OFF once you have confirmed that the Quartz Tube is not leaking.

4D. Re-installing the UV Lamp(s)

NOTE: Make sure to handle the UV lamp as described in **SECTION 4B**.

1. TURN OFF YOUR PUMP IF YOU HAVE NOT DONE SO.
2. Allow UV Lamp to drop slowly into the Quartz Tube until it is seated in the Lamp Cushion in the bottom of the tube.
3. Connect the Lamp Connectors, Pressure Switch Connectors and Power Connectors.

ENVIRONMENTAL NOTICE: Hg-Lamp CONTAINS MERCURY.

Manage in accordance with disposal laws. See: www.lamprecycle.org

Section 5 Troubleshooting

5A. Troubleshooting

Knowledge of electrical applications is required for troubleshooting. We recommend that a certified electrician service the equipment. Improper servicing will void generator warranty. If any condition persists contact Technical Support (see **SECTION 6A**).

Symptom: Green Indicator not lit when pool system is on.

1. No power to the UV-C 50 from the Power Source:
 - a. Check circuit breaker at the power distribution box.
 - b. Check for loose connections or wiring breaks in the lines.
 - c. Indicator light may have burnt out.

Symptom: One or both the UV Lamps are not lit when unit is running.

1. Check Lamp Connector Plug for complete connection.
2. Water fouling has shorted lamp connections.
3. Bad UV Lamp.
4. Bad Ballast.

Section 6 Contact Information

6A. Contact Information

For technical assistance:

- Call: 1 (800) 676-1335
- Email: o3info@delozone.com

Be prepared with the following information:

- Name
- Address
- Model #
- Date Purchased

6B. Ordering Information

To locate a dealer near you, call us at 1 (800) 676-1335, and we'll be happy to help.

6C. Standard Replacement Parts List

1. UV Lamps (Replace every 18 months) 9-1197-01
2. Quartz Tube Assembly (replace as needed)..... 9-1416-01



CMP, LLC
36 HERRING ROAD, NEWNAN, GA 30265
WWW.C-M-P.COM

1217Im